



Shown from left to right:
ESL-1000, ESL-1002, ESL-50, ESL-500, ESL-302

ESL-SERIES SINGLE ACTING, LOW HEIGHT CYLINDERS

Features

- ◆ Use in confined spaces.
- ◆ Complies with ASME B30.1. High strength steel for durability and increased safety.
- ◆ Mounting holes permit easy fixturing.
- ◆ Heavy-duty piston return spring.
- ◆ High quality EAB-201 quick couplers.
- ◆ Grooved piston end requires no saddle.
- ◆ Environmentally friendly painting process provides a durable anti-corrosion finish.

Pressure gauges available to monitor system pressure



Quality pressure hoses



Cylinder Capacity @ 700 Bar (10,000 PSI)	Stroke	Model	Cylinder Effective Area	Oil Capacity	Collapsed Height	
					A	in
Metric Ton (US Ton)	in		in ²	in ³		
5 (5.5)	0.24	ESL-50	1.10	0.26	1.30	
10 (11)	0.39	ESL-100	2.25	0.88	1.65	
20 (22)	0.43	ESL-200	4.39	1.90	2.01	
30 (33)	0.51	ESL-300	6.48	3.31	2.30	
50 (49)	0.63	ESL-500	9.86	6.21	2.64	
75 (82.5)	0.63	ESL-750	16.10	10.14	3.11	
100 (102.2)	0.63	ESL-1000	20.58	12.96	3.39	
150 (154.8)	0.63	ESL-1500	31.17	19.63	3.94	



24 EAGLE PRO ESL series hydraulic cylinders with an EAGLE PRO electric hydraulic pump lift a bridge into position

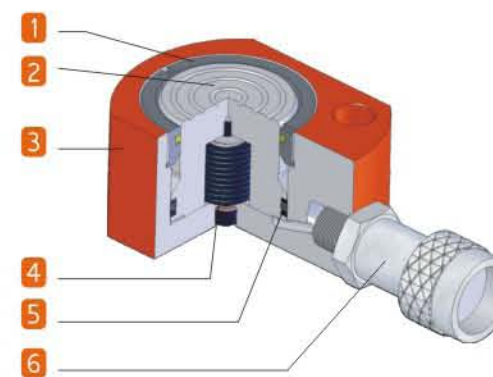

1. Steel guide ring eliminates over travel and withstands full dead end load, it also provides support to reduce wear from off center loads.
2. Hardened and chromed piston increase durability and reduces wear.
3. All steel body with baked enamel finish for durability.
4. High strength return spring.
5. Secondary gasket and industrial seal ring assembly prevent costly leaks.
6. Standard coupler on all cylinders provided with heavy duty dust cover.

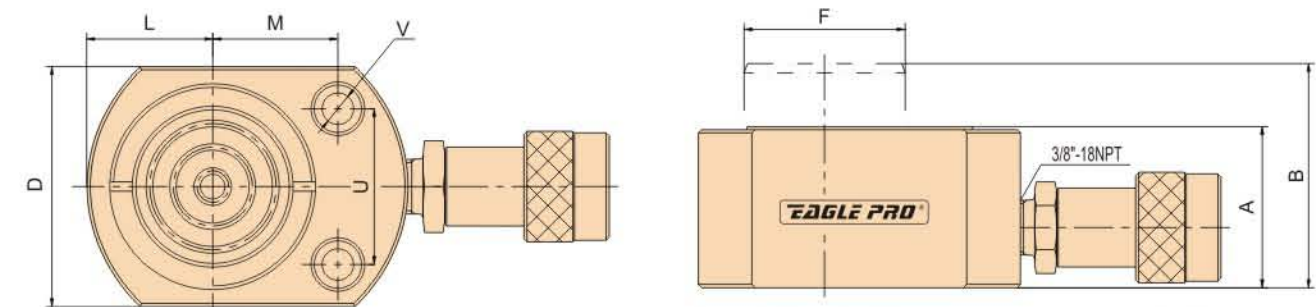

Note: ESL-50 has EAB-203A coupler, The other models have EAB-201A coupler.

Extended Height	Outside Diameter	Piston Rod Diam.	Upside Dimension				Weight	Model
			M	L	V	U		
B	D	F	M	L	V	U		
in	in	in	in	in	in	in	lbs	
1.54	2.32 × 1.65	0.98	0.91	0.83	0.22	1.12	1.3	ESL-50
2.09	3.27 × 2.20	1.50	1.34	1.10	0.28	1.44	3.3	ESL-100
2.44	3.98 × 3.00	2.01	1.57	1.57	0.39	1.94	5.9	ESL-200
2.80	4.61 × 3.74	2.60	1.77	1.89	0.39	2.05	9.5	ESL-300
3.27	5.51 × 4.49	2.76	2.13	2.24	0.43	2.62	14.7	ESL-500
3.74	6.50 × 5.47	3.27	2.60	2.72	0.53	3.00	25.1	ESL-750
4.02	7.01 × 6.02	3.62	2.91	2.99	0.53	3.00	31.9	ESL-1000
4.57	8.46 × 7.48	4.53	3.23	3.74	0.53	4.62	57.9	ESL-1500