

Features

- ◆ Hollow piston design allows for both pull and push forces.
- ◆ Complies with ASME B30.1. High strength steel for durability and increased safety.
- ◆ Single-acting, spring return.
- ◆ High quality EAB-201 and EAB-202 quick couplers.
- ◆ Collar threads, piston threads for easy fixturing.
- ◆ Environmentally friendly painting process provides a durable anti-corrosion finish.



Shown from left to right:
ESH-302, ESH-120

ESH-SERIES SINGLE ACTING HOLLOW CENTER CYLINDERS

Optional Heat Treated Hollow Saddles

Cylinder Model Number	Saddle Model Number	Saddle Dimensions				
		A in	B mm	C in	D mm	
ESH-202, 206	SH-2015	2.09	1"-8UNC	0.35	1 9/16"-16UN	
ESH-302, 306	SH-3015	2.48	1 1/4"-7UN	0.35	1 13/16"-16UN	
ESH-603, 606	SH-5016	3.58	1 5/8"-5 1/2UN	0.47	2 3/4"-16UN	
ESH-1003	SH-10016	4.96	2 1/2"-8UN	0.51	4"-16UN	

Cylinder Capacity @ 700 Bar (10,000 PSI)	Stroke	Model	Cylinder Effective Area	Oil Capacity	Collapsed Height		Extended Height		Collar Thread	Collar Thread Length	Outside Diameter	Piston Rod Diam.
					A	B	C	X				
Metric Ton (US Ton)	in		in ²	in ³	in	in	in	in	in	in	in	
13 (14.3)	0.31	ESH-120	2.87	0.90	2.17	2.48	2 3/4"-16	1.18	2.76	1.38		
	1.65	ESH-121	2.87	4.74	4.72	6.38	2 3/4"-16	1.18	2.76	1.38		
	2.99	ESH-123	2.87	8.58	7.24	10.24	2 3/4"-16	1.18	2.76	1.38		
20 (22)	1.93	ESH-202	5.08	9.80	6.38	8.31	3 7/8"-12	1.50	3.90	2.17		
	6.10	ESH-206	5.08	31.01	12.05	18.15	3 7/8"-12	1.50	3.90	2.17		
30 (33)	2.52	ESH-302	7.39	18.62	7.01	9.53	4 1/2"-12	1.65	4.53	2.56		
	6.10	ESH-306	7.39	45.10	12.99	19.09	4 1/2"-12	1.65	4.53	2.56		
60 (66)	2.99	ESH-603	13.56	40.57	9.69	12.68	6 1/4"-12	1.89	6.26	3.62		
	6.02	ESH-606	13.56	81.66	12.72	18.74	6 1/4"-12	1.89	6.26	3.62		
95 (104.5)	2.99	ESH-1003	20.97	62.73	10.00	12.99	8 3/8"-12	2.36	8.35	5.00		

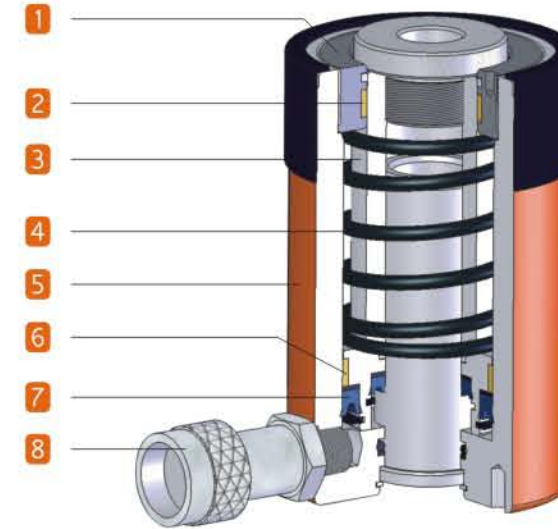

1. Steel Guide ring eliminates over travel, and provides support to reduce wear from off center loads.
2. Bearing ring provides additional support to reduce wear from off center loads.
3. Hardened and chromed piston increase durability and reduces wear.
4. High strength return spring.
5. All steel body with baked enamel finish for durability.
6. Industrial bearing ring provides additional support to reduce wear from off center loads.
7. Industrial seal ring assembly prevent costly leaks.
8. Standard coupler on all cylinders provided with heavy duty dust cover.



4 EAGLE PRO ESH-306 pulling threaded bar in a the largest heat exchanger in SONDEX's factory in Ningbo China.

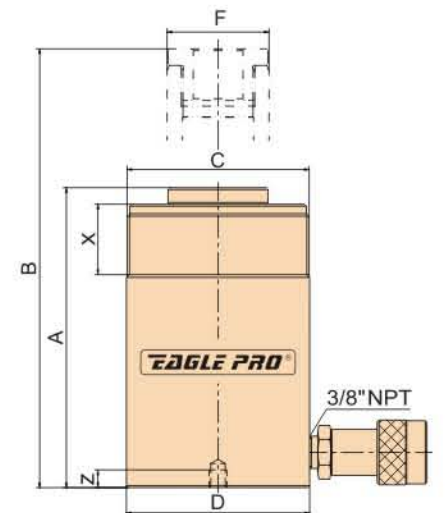
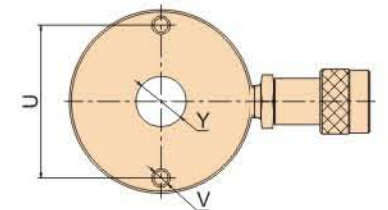

Bolt Circle	Base Fix Holes		Center Hole Diameter	Weight	Model
	Thread	Thread Depth			
U	V	Z	Y	lbs	
2.00	5/16"-18	0.35	0.77	3.3	ESH-120
—	—	—	0.77	6.16	ESH-121
2.00	5/16"-18	0.35	0.77	9.68	ESH-123
3.25	3/8"-16	0.37	1.06	16.06	ESH-202
3.25	3/8"-16	0.37	1.06	29.48	ESH-206
3.63	3/8"-16	0.55	1.31	23.1	ESH-302
3.63	3/8"-16	0.55	1.31	42.46	ESH-306
5.13	1/2"-13	0.55	2.12	60.28	ESH-603
5.13	1/2"-13	0.55	2.12	76.56	ESH-606
7.00	5/8"-11	0.79	3.11	130.9	ESH-1003

Note:ESH-120, ESH-121 and ESH-123 have EAB-202A coupler, and 1/4" NPT port. The other models have EAB-201A coupler and 3/8" NPT port.